

Test: Primary 6 Science (Prelim) - MGS (Y0)

Points: 29 points

Name: _____

Score: _____

Date: _____

Signature: _____

Select multiple choice answers with a cross or tick:

- Only select one answer
- Can select multiple answers

Question 1 of 59

Primary 6 Science (Prelim) 1 pt

The classification chart shows how some living things can be classified.

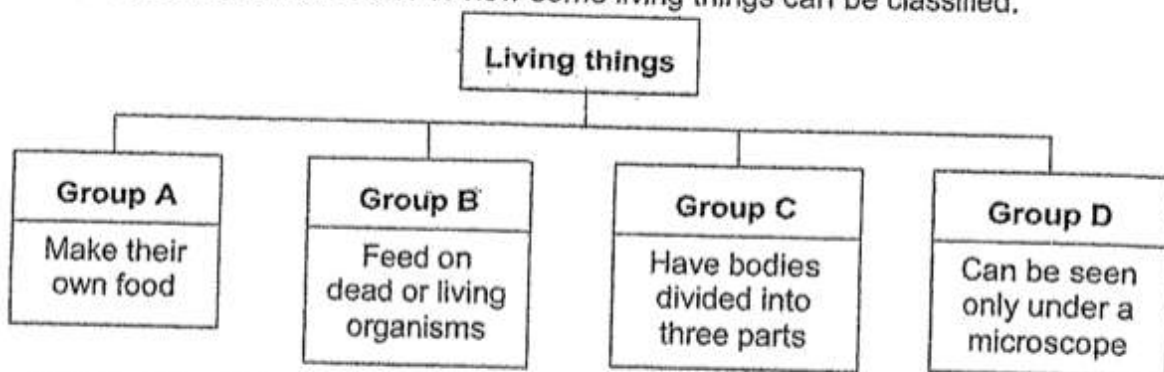

Which of the following can be placed in Groups A, B, C and D respectively?

	Group A	Group B	Group C	Group D
(1)	insects	plants	bacteria	fungi
(2)	flowering plants	fungi	bacteria	insects
(3)	non-flowering plants	fungi	insects	bacteria
(4)	non-flowering plants	bacteria	insects	fungi

- A) 1
- B) 2
- C) 3
- D) 4

Question 2 of 59

Primary 6 Science (Prelim)

1 pt

The diagram below shows an air pump attached to a deflated tyre by a tube.

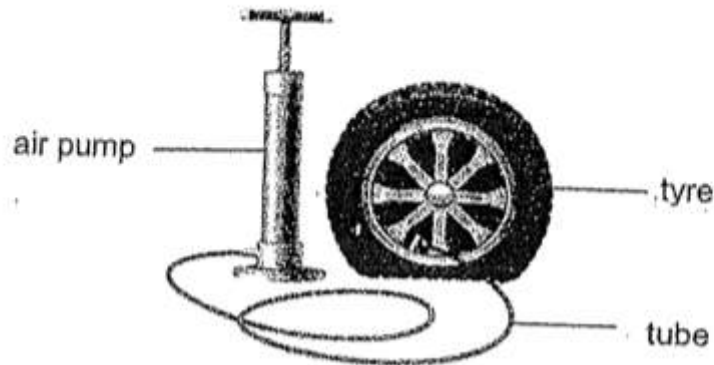

What happens to the mass and volume of the tyre after four pumps of air are given?

	Mass	Volume
(1)	increases	increases
(2)	no change	increases
(3)	increases	no change
(4)	decreases	decreases

-
- A) 1
- B) 2
- C) 3
- D) 4

Question 3 of 59

Primary 6 Science (Prelim)

1 pt

Shucheng sealed 4 similar pieces of bread into an airtight bag each and placed them under different conditions as shown below. The bread in Bag Y was toasted before being sealed.

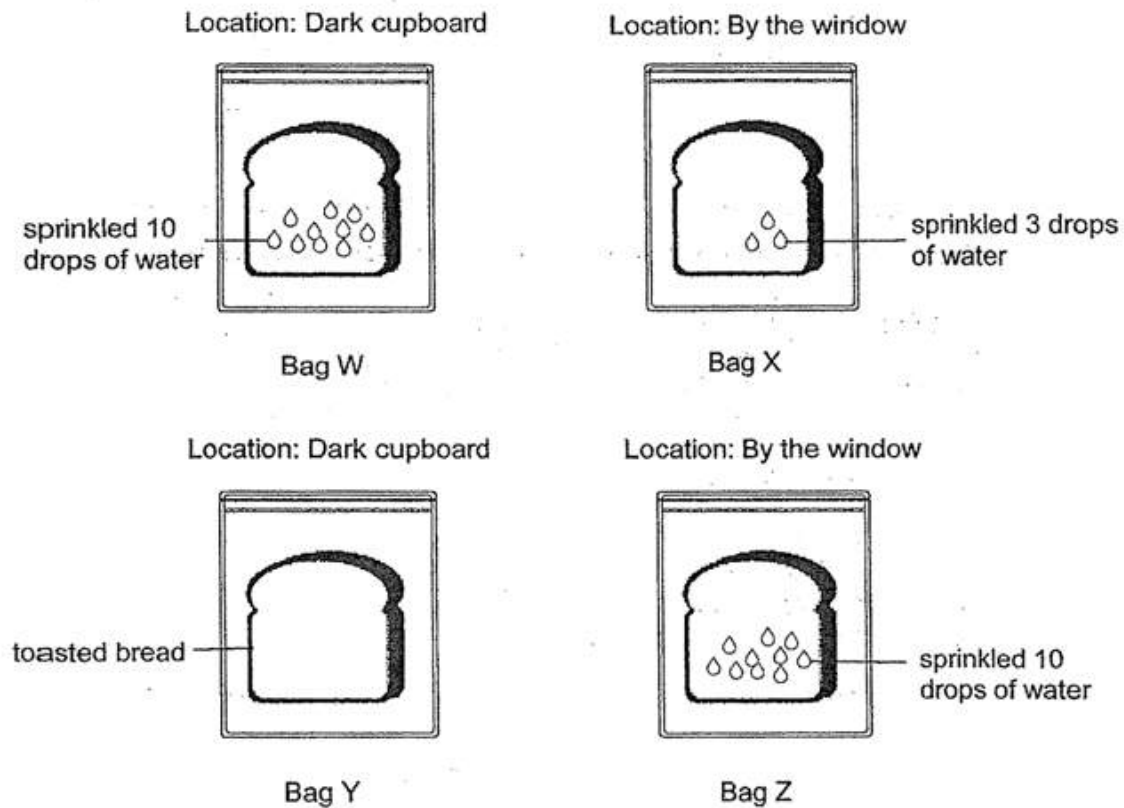

Which of the following correctly shows the aim of his experiment based on the bags that he has chosen for comparison?

	Bags	Aim of experiment
(1)	W and X	To find out if air is required for mould to grow
(2)	W and Z	To find out if light is required for mould to grow
(3)	X and Y	To find out if moisture is required for mould to grow
(4)	Y and Z	To find out if warmth is required for mould to grow

- A) 1
 B) 2
 C) 3
 D) 4

Question 4 of 59

Primary 6 Science (Prelim)

1 pt

The diagrams below show parts of the reproductive system in a plant and in a human.

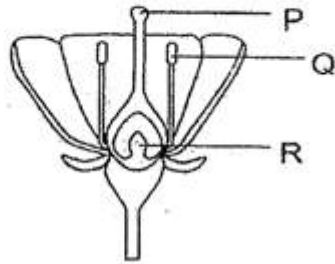

plant reproductive system

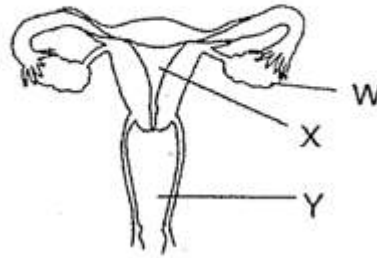

human reproductive system

Some students made the following statements shown in the table below.

Student	Statement
Andy	Fertilisation takes place at R, X and W.
Janelle	Q and W produce reproductive cells.
Ismail	Both P and Y receive the female reproductive cells.

Which of the student(s) is/are correct?

- A) Janelle only
- B) Andy and Ismail only
- C) Janelle and Ismail only
- D) Andy, Janelle and Ismail

Question 5 of 59

Primary 6 Science (Prelim)

1 pt

The classification table below shows how some animals are classified.

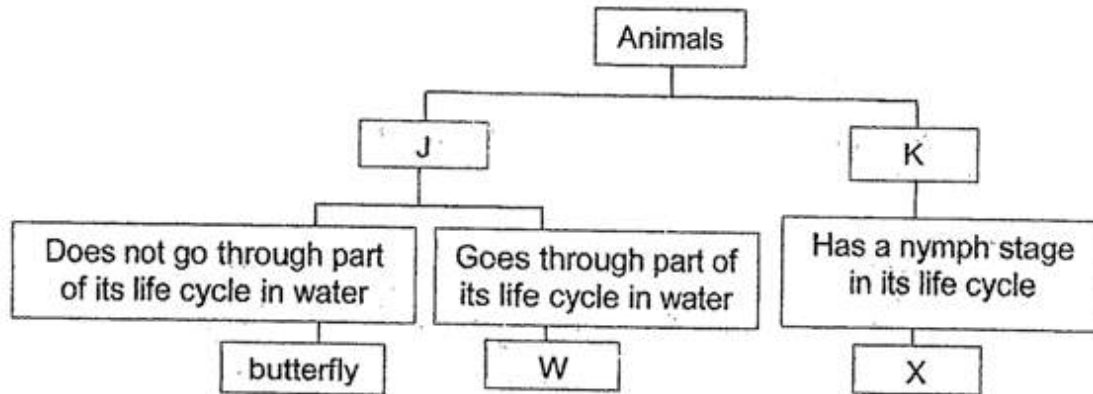

Which of the following best represent J, K, W and X?

	J	K	W	X
(1)	Has a 3-stage life cycle	Has a 4-stage life cycle	beetle	grasshopper
(2)	Has a 4-stage life cycle	Has a 3-stage life cycle	mosquito	cockroach
(3)	Young resembles the adult	Young does not resemble the adult	beetle	cockroach
(4)	Young does not resemble the adult	Young resembles the adult	mosquito	beetle

- A) 1
 B) 2
 C) 3
 D) 4

Question 6 of 59

Primary 6 Science (Prelim)

1 pt

Samy wanted to find out how the number of wing-like structures of Fruit C affects the time it takes to reach the ground.

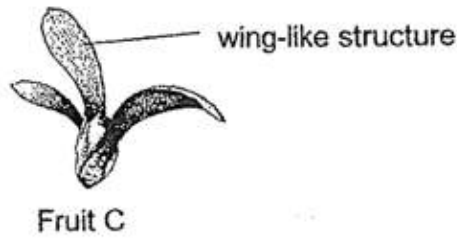

He carried out an experiment using four set-ups, W, X, Y and Z, and recorded his observations in the table below.

Set-ups	Number of wing-like structures	Colour of fruit C	Presence of wind
W	1	brown	Yes
X	1	black	Yes
Y	3	black	Yes
Z	3	brown	No

Which two set-ups should he choose for a fair test?

-
- A) W and X
 B) W and Y
 C) Z and X
 D) Z and Y

Question 7 of 59

Primary 6 Science (Prelim)

1 pt

The diagram shows parts of the digestive system.

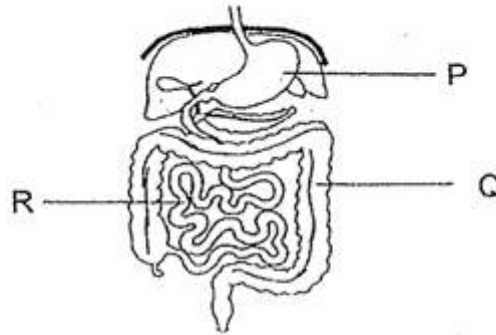

Which of the following statements are correct?

- A Digestion is completed at Q.
- B Digested food is absorbed in Q and R.
- C Digestive juices can be found in P and R.
- D Water is removed from undigested food at Q.

-
- A) A and B only
 - B) A and C only
 - C) D and B only
 - D) D and C only

Question 8 of 59

Primary 6 Science (Prelim)

1 pt

Molly carried out an experiment using four different water samples, P, Q, R and S. Using the same amount of water sample and water plants, she set up the experiment as shown below.

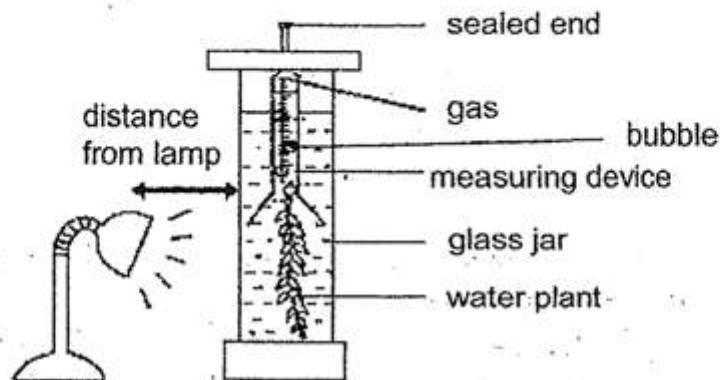

After 6 hours, the volume of gas produced by the water plants in each water sample was recorded in the table below.

Water sample	Volume of gas (cm ³)
P	18
Q	9
R	5
S	11

Based on her results, which of the following statements is **incorrect**?

- A) sample P is clearer than sample S
- B) the amount of light passing through sample R is the least
- C) the water plant in sample p made the most amount of food
- D) the rate of photosynthesis for the water plan in sample Q is higher than that in sample S

Question 9 of 59

Primary 6 Science (Prelim)

1 pt

Which one of the following diagrams shows the correct paths taken by food and water as they are transported in a plant?

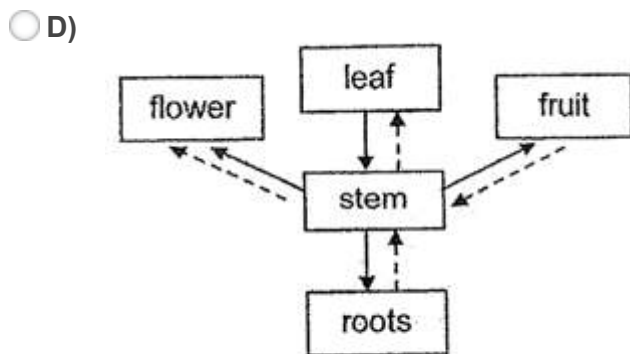
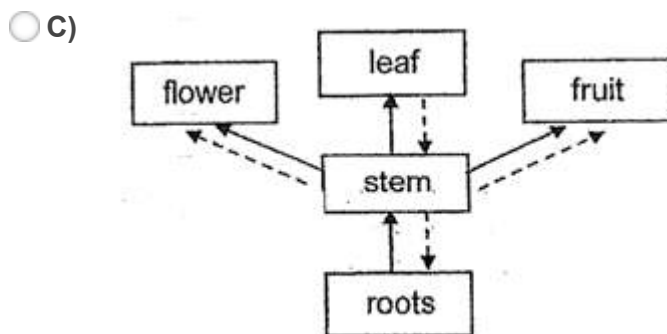
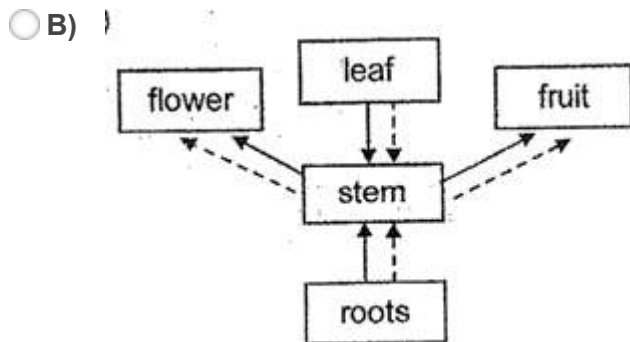
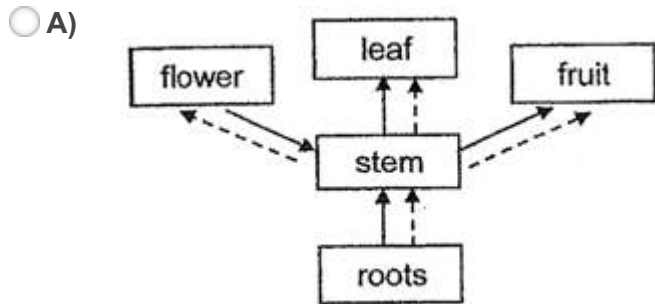
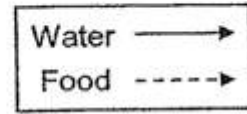

Question 10 of 59

Primary 6 Science (Prelim)

1 pt

The flow chart below shows information on four type of cells, A, B, C and D.

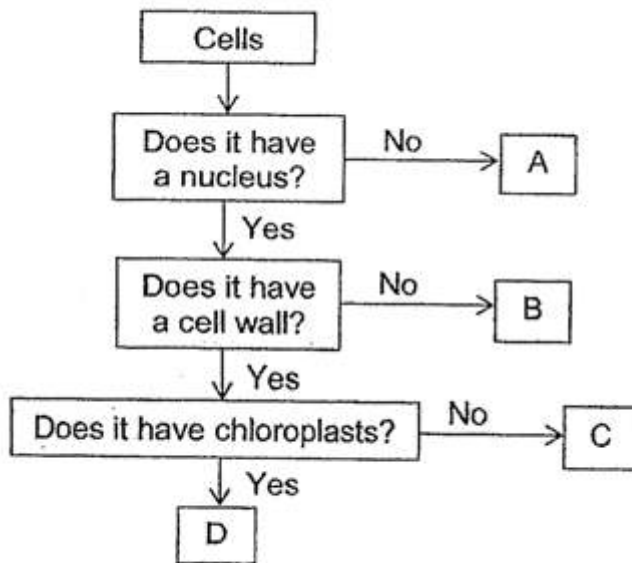

Which cell is found on a plant part that produces sugar?

-
- A) A
- B) B
- C) C
- D) D

Question 11 of 59

Primary 6 Science (Prelim)

1 pt

Nabil set up an experiment to investigate the rate of evaporation of water. He set up a beaker of water in the Science Room and measured the volume of water left in the beaker over a period of time. He recorded his results in the graph below.

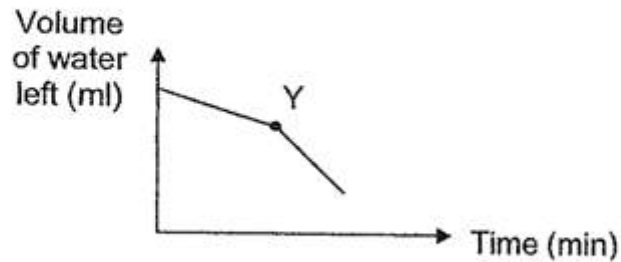

Which one of the following changes did Nabil make to his set-up at point Y of the graph?

-
- A) he placed the beaker in the freezer
 - B) he poured boiling water into the beaker
 - C) he switched on the fans in the science room
 - D) he poured the water into another beaker with a smaller opening

Question 12 of 59

Primary 6 Science (Prelim)

1 pt

Iris poured 500 ml of water into two identical beakers, P and Q, and placed a plant into beaker P as shown below.

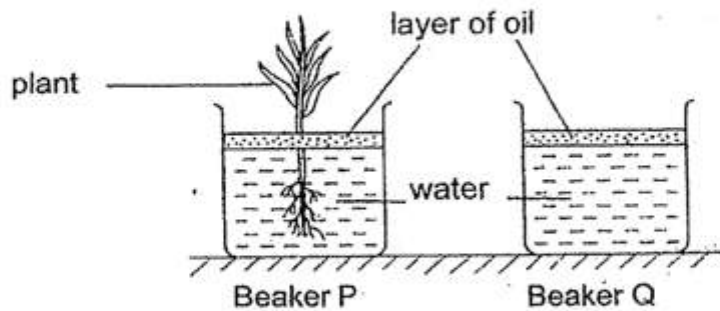

She left both beakers by a window in the living room and recorded the volume of water left in both beakers over a few days. Which one of the following graphs correctly shows the volume of water left in both beakers?

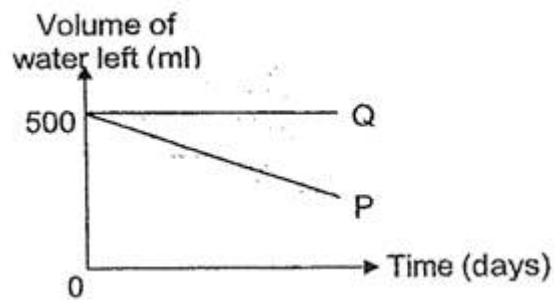
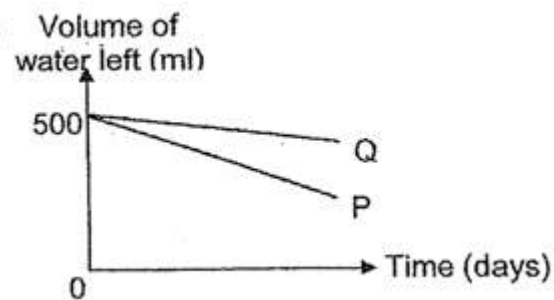
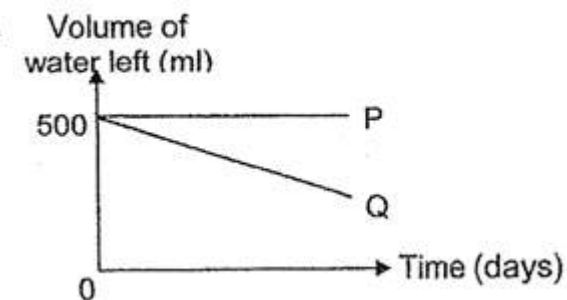
 A)

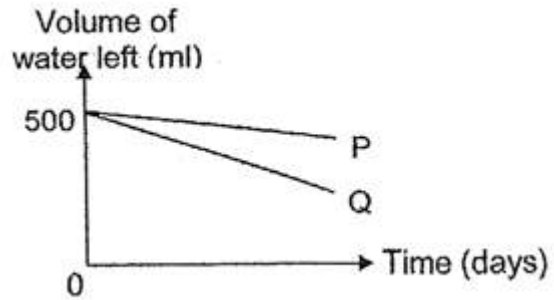
 B)

 C)

 D)



Question 13 of 59

Primary 6 Science (Prelim)

1 pt

Natalie used the set-up below to investigate the flexibility of 3 strips, J, K and L, which are made of different materials.

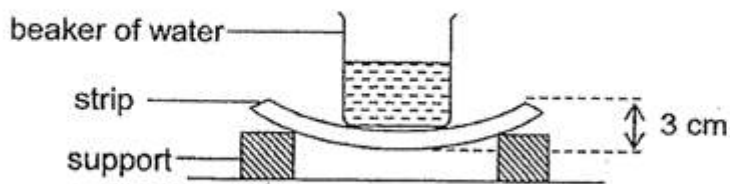

She placed strip J on two supports and poured water into an empty beaker until strip J bent by 3 cm. She repeated the experiment for strips K and L. She recorded the amount of water required to bend each strip by 3 cm and concluded that strip L is the most flexible and strip K is the least flexible.

Which of the following shows the correct amount of water in the beaker required to bend the strips by 3 cm?

	Amount of water in beaker (cm ³)		
	J	K	L
(1)	100	250	500
(2)	250	100	500
(3)	500	250	100
(4)	250	500	100

- A) 1
 B) 2
 C) 3
 D) 4

Question 14 of 59

Primary 6 Science (Prelim)

1 pt

Nathaniel used a bunsen burner to heat a beaker containing a block of ice. He measured the temperature of the content in the beaker from the start of the experiment for a period of time and plotted the graph below.

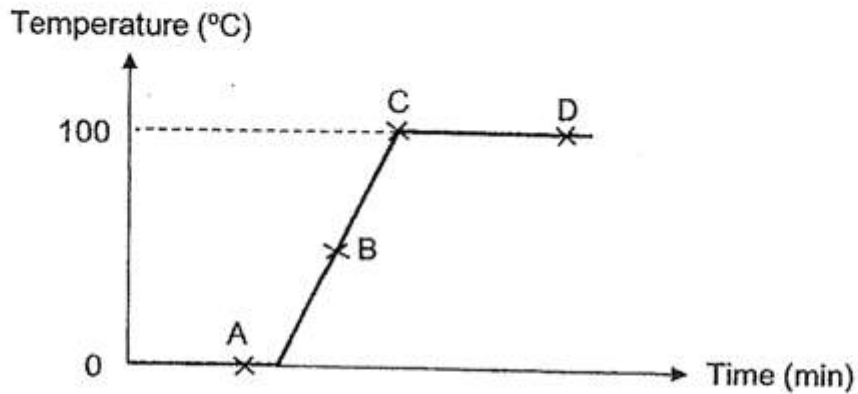

At which points on the graph can he find water in the following states?

	liquid and gas	liquid only	solid and liquid
(1)	C and D	B	A
(2)	D	B	A
(3)	none	C	A and B
(4)	none	C, D	A and B

- A) 1
 B) 2
 C) 3
 D) 4

Question 15 of 59

Primary 6 Science (Prelim)

1 pt

Janice had 150 cm^3 of plasticine. She moulded all of it into a ball, placed it into a container of water and recorded the total volume of water and plasticine. Next, she took the ball out and rolled it into two cubes before placing it back into the container of water as shown below.

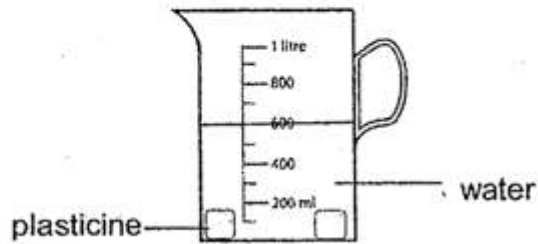

Which of the following represents (A) the volume of water used in the experiment and (B) the total volume of water and one cube of plasticine that Janice could record?

	(A) Volume of water (cm^3)	(B) Total volume of water and one cube of plasticine (cm^3)
(1)	450	150
(2)	525	750
(3)	450	525
(4)	600	750

- A) 1
 B) 2
 C) 3
 D) 4

Question 16 of 59

Primary 6 Science (Prelim)

1 pt

Zalina wanted to find out if the arrangement of bulbs affects the brightness of the bulbs in a circuit.

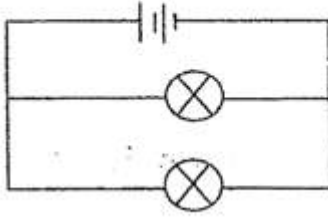

Circuit A

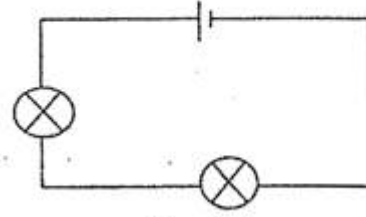

Circuit B

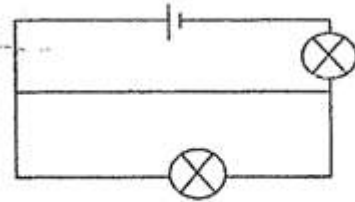

Circuit C

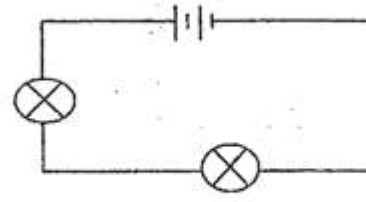

Circuit D

Which two circuits should she use to carry out the experiment?

- A) A and B only
- B) A and D only
- C) C and B only
- D) C and D only

Question 17 of 59

Primary 6 Science (Prelim)

1 pt

Sara used a circuit tester to test the properties of three bars, P, Q and R. She recorded the results as shown in the table below.

Observation	Bars		
	P	Q	R
Did the bulb light up?	Yes	No	Yes
Did the bar attract steel clips?	Yes	No	No

She used the following flow chart to classify the bars based on their properties.

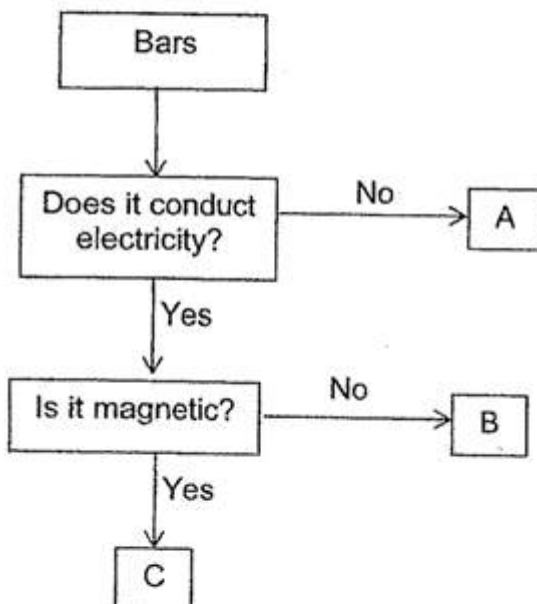

Which of the following letters can be used to represent bars P, Q and R?

	Bars		
	P	Q	R
(1)	A	B	C
(2)	B	C	A
(3)	B	A	C
(4)	C	A	B

- A) 1
 B) 2
 C) 3
 D) 4

Question 18 of 59

Primary 6 Science (Prelim)

1 pt

Suresh poured equal amount of tap water into 3 identical beakers. He added 7 ice cubes into each beaker. After that, he wrapped each beaker with a different number of identical bubble wraps of the same size.

Beaker	Number of bubble wraps used to wrap the beaker
A	13
B	2
C	7

After some time, he removed all the bubble wraps and made his observations as shown below.

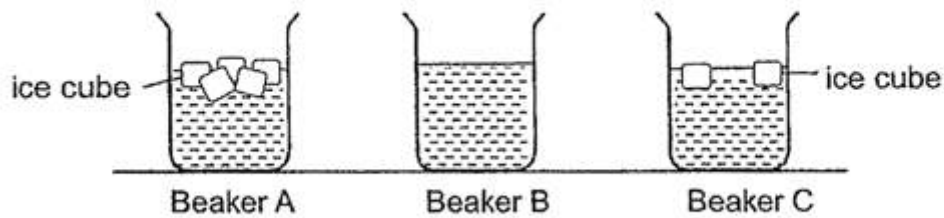

Which statement explains Suresh's observations?

- A) 1
- B) 2
- C) 3
- D) 4

Question 19 of 59

Primary 6 Science (Prelim)

1 pt

Suresh poured equal amount of tap water into 3 identical beakers. He added 7 ice cubes into each beaker. After that, he wrapped each beaker with a different number of identical bubble wraps of the same size.

Beaker	Number of bubble wraps used to wrap the beaker
A	13
B	2
C	7

After some time, he removed all the bubble wraps and made his observations as shown below.

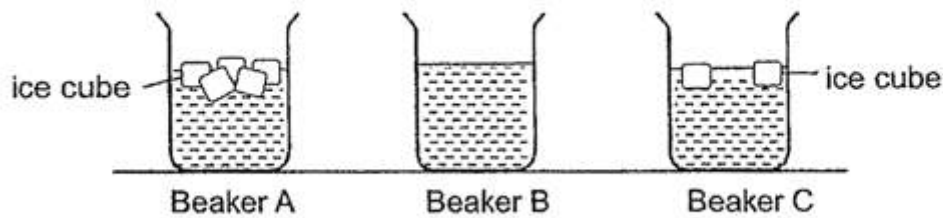

Which statement explains Suresh's observations?

- A) The ice cubes in beaker C gained more heat than the ice cubes in beaker B
- B) The more bubble wraps used, the more heat is trapped to prevent the ice from melting
- C) Beaker B has the least bubble wraps used so the greatest amount of heat is lost from the ice cubes
- D) Beaker A has the most bubble wraps used so the ice cubes in it gained the least amount of heat

Question 20 of 59

Primary 6 Science (Prelim)

1 pt

John placed 4 similar uncooked eggs into beakers, A, B, C and D, which contained water of different volumes and temperatures as shown in the diagrams. The eggs were left in the water over a period of time.

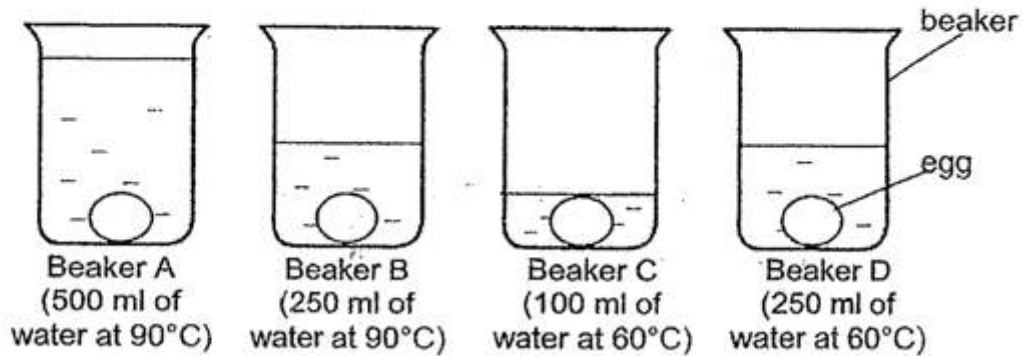

John then cracked each egg to observe how cooked it was.

Which one of the following shows the correct order of how cooked each egg was?

	least cooked	—————→		most cooked
(1)	C	D	B	A
(2)	C	B	D	A
(3)	A	B	D	C
(4)	A	D	B	C

- A) 1
 B) 2
 C) 3
 D) 4

Question 21 of 59

Primary 6 Science (Prelim)

1 pt

A measuring cylinder containing some amount of water at 10°C is placed in a beaker containing 100 ml of oil at 70°C . The set-up was left in the room for some time.

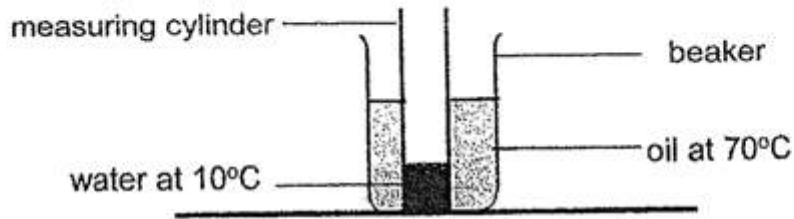

Four pupils made the following statements.

Jane: The temperature of water increased after some time as it gained heat from the oil.

Mary: The temperature of oil decreased after some time as it lost heat to the water and surroundings.

Kathy: Heat is transferred from the oil to the water.

Who made the correct statement(s)?

-
- A) Kathy only
- B) Jane and Kathy only
- C) Jane and Mary only
- D) Jane, Mary and Kathy

Question 22 of 59

Primary 6 Science (Prelim)

1 pt

A ball was attached to a string and released from position A. It swung from position A to D as shown below.

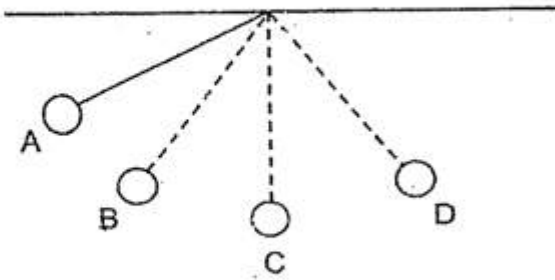

At which position, A, B, C or D, did the ball possess the most kinetic energy?

- A) A
- B) B
- C) C
- D) D

Question 23 of 59

Primary 6 Science (Prelim)

1 pt

Jenny conducted an experiment in a dark room with two different toy cars, X and Y. Car X was first placed at the starting line as shown in the diagram. Jenny turned on its switch and Car X moved towards the finishing line. The amount of light detected by the light sensor as the car moved for five seconds was recorded.

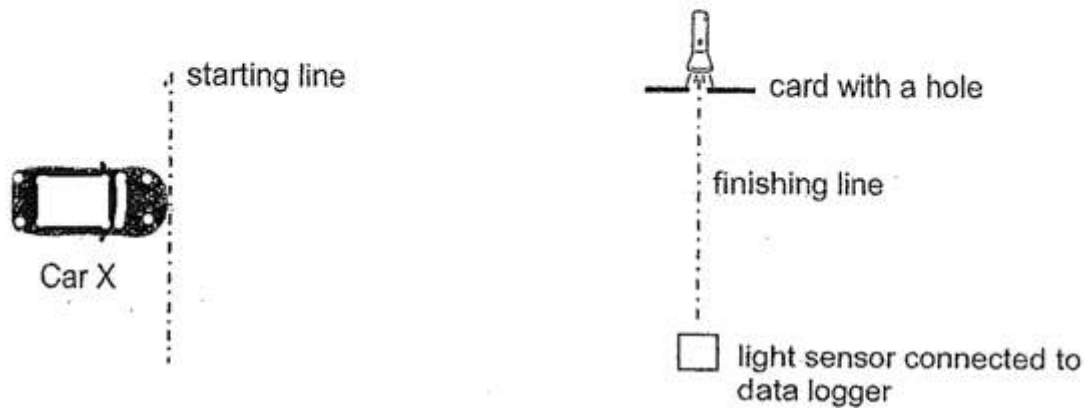

She repeated the experiment with Car Y. Her results are shown in the table below.

Time (s)	Amount of light detected by light sensor (units)	
	Car X	Car Y
0	2000	2000
1	2000	2000
2	0	2000
3	2000	2000
4	2000	0
5	2000	2000

Based on the above results, which of the following statements are correct?

- A Car X travelled faster than Car Y.
- B Car Y has a brighter colour than Car X.
- C Car X allows more light to pass through.
- D Car Y reached the finishing line at the 4th second.

- A) A and C only
- B) A and D only
- C) B and D only
- D) C and D only

Question 24 of 59

Primary 6 Science (Prelim)

1 pt

Muthu released a wooden block down a slope causing it to move from position A to B as shown in Diagram X. The graph below shows the amount of three different forms of energy of the wooden block at position L of the slope.

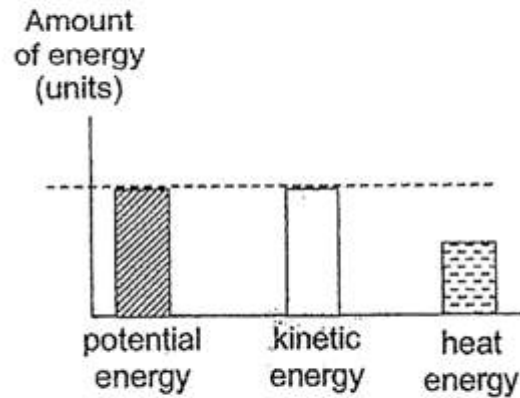
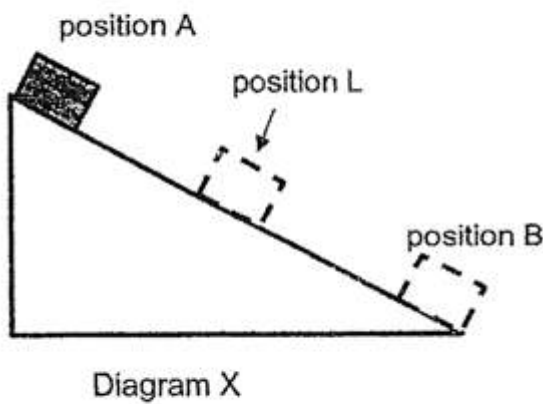

Muthu applied some powder on the slope and repeated the experiment. Which one of the following graphs show the amounts of different forms of energy in the wooden block when it is at position L?

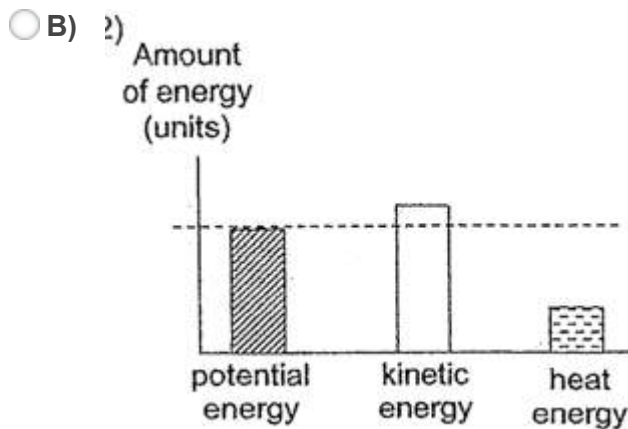
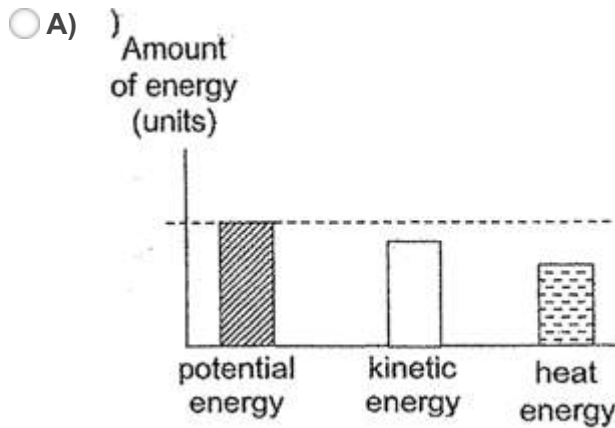

C)

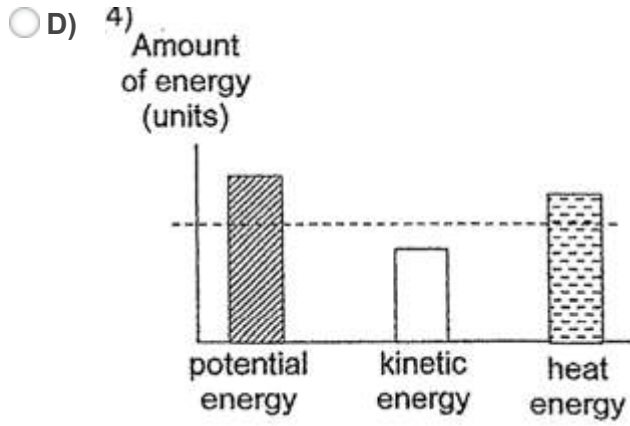
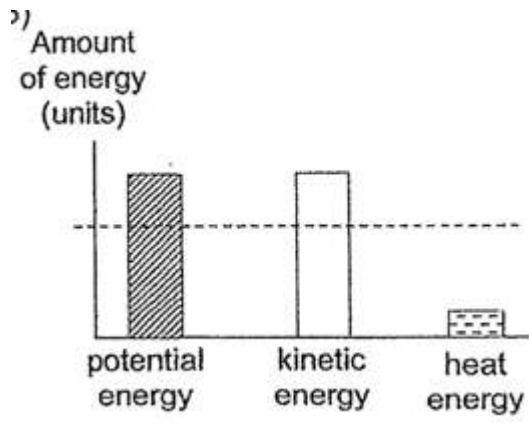

Question 25 of 59

Primary 6 Science (Prelim)

1 pt

The diagram below shows the path taken by the ball travelled when it was kicked. It then travelled to points A, B and C as shown in the diagram below.

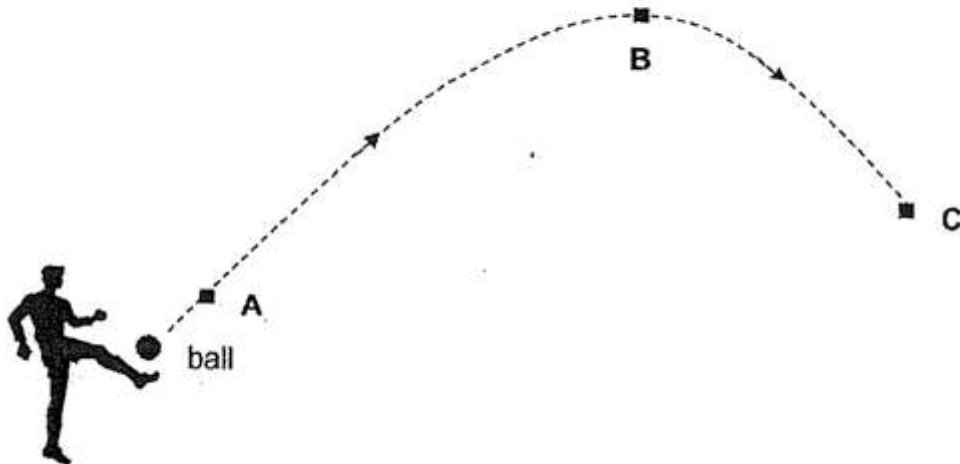

Which one of the following graphs shows the amount of gravitational force acting on the ball at points A, B and C?

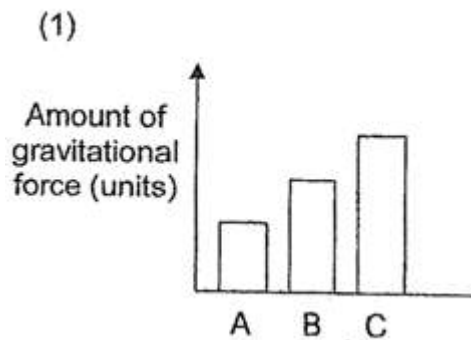
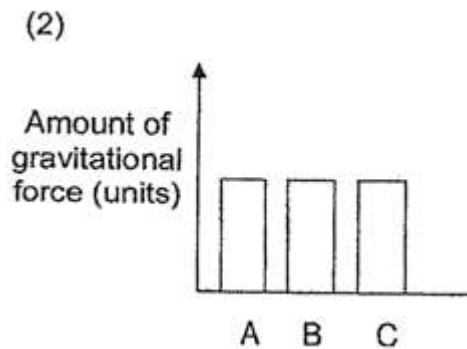
 A)

 B)

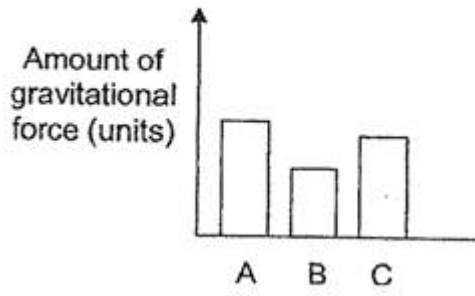
 C)

(3)

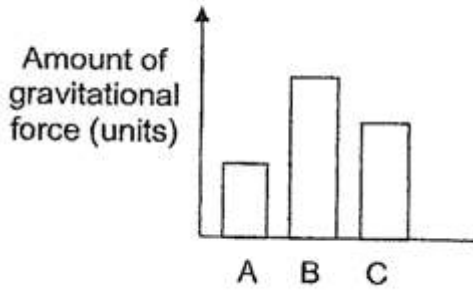

D)

(4)



Question 26 of 59

Primary 6 Science (Prelim)

1 pt

Anna labelled the ends of three metal bars A, B and C as shown.

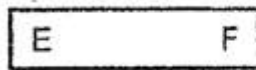

metal bar A

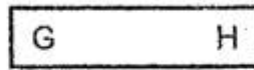

metal bar B

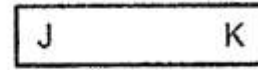

metal bar C

She brought the ends of the metal bars close to each other and made some observations.

F and G attracted each other



F and H repelled each other



E and J attracted each other



F and J attracted each other



Based on her observations, which one of the following statements is **not** correct?

- A) Bar B can attract bar C
- B) Bar A and bar B are magnets
- C) Bar A and bar C are magnets
- D) Bars A, B and C are made of magnetic materials

Question 27 of 59

Primary 6 Science (Prelim)

1 pt

The picture shows a man pushing a box along the floor.

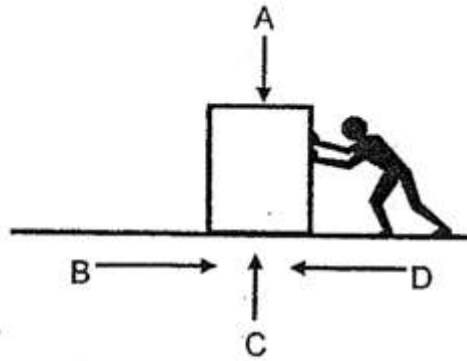

Which of the following correctly identify the arrows to the type of forces acting on the box?

	Gravitational force	Frictional Force
(1)	A	B
(2)	A	D
(3)	B	C
(4)	C	B

- A) 1
 B) 2
 C) 3
 D) 4

Question 28 of 59

Primary 6 Science (Prelim)

1 pt

A mass was hung on a spring and its extension was recorded as shown in the graph below.

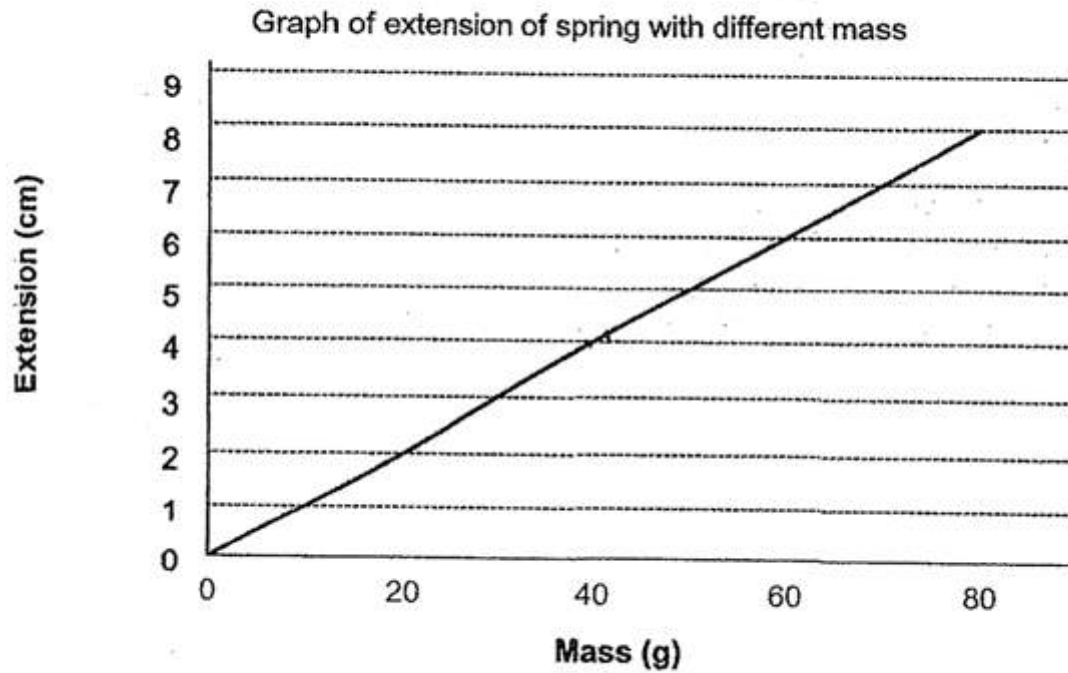

The original length of the spring was 10 cm. What was the length of the spring when a mass of 40 g was hung on it?

- A) 4 cm
- B) 8 cm
- C) 12 cm
- D) 14 cm

Question 29 of 59

Primary 6 Science (Prelim) 0 pts

Some students observed the parts of 3 different cells, X, Y and Z, under a microscope. They recorded their observations in the table below. A tick (✓) indicates that the cell part was present.

Parts	Cells		
	X	Y	Z
Nucleus	✓	✓	✓
Cell membrane	✓	✓	✓
Cytoplasm	✓	✓	✓
Cell wall		✓	✓
Chloroplast		✓	

- (a) Based on the results above, what is the main difference between the functions of Cells Y and Z? [1]

Question 30 of 59

Primary 6 Science (Prelim) 0 pts

The students observed another Cell K as shown below.

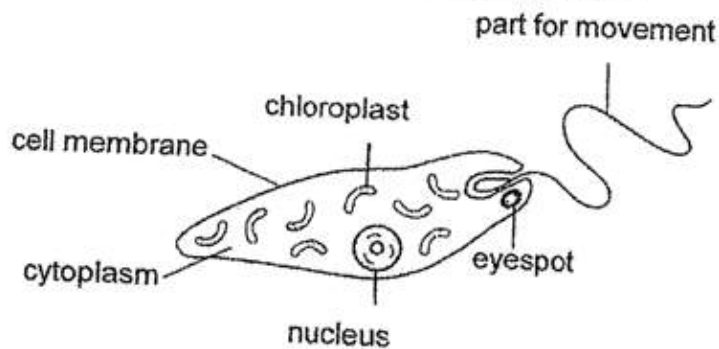

- (b) State a characteristic of Cell K which shows that it is taken from the same group of living things as Cell X. [1]

Question 31 of 59

Primary 6 Science (Prelim) 0 pts

The diagram shows two flowers, X and Y, from the same plant. After process J happens, fertilization takes place in flower X and a fruit develops.

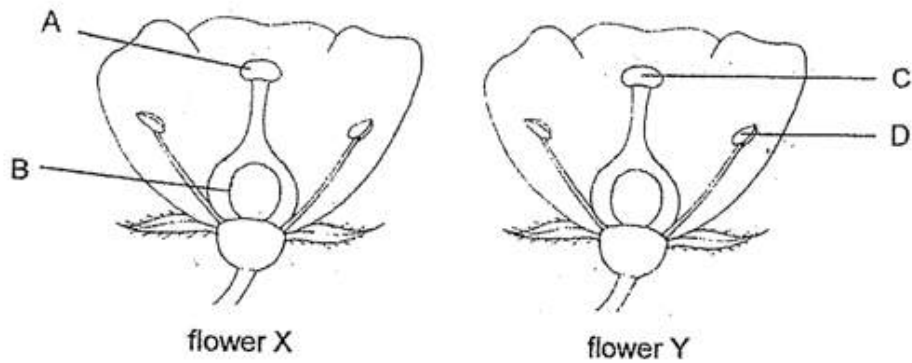

- (a) Using the labelled part(s) in the diagram above, explain what happens during process J. [1]

Question 32 of 59

Primary 6 Science (Prelim) 0 pts

- b) Flowers X and Y contain a lot of nectar. Explain how both flowers are likely to be pollinated

Question 33 of 59

Primary 6 Science (Prelim) 0 pts

- 1 The graph below shows the volume of blood supplied to some parts of Melvin's body when he is resting and exercising.

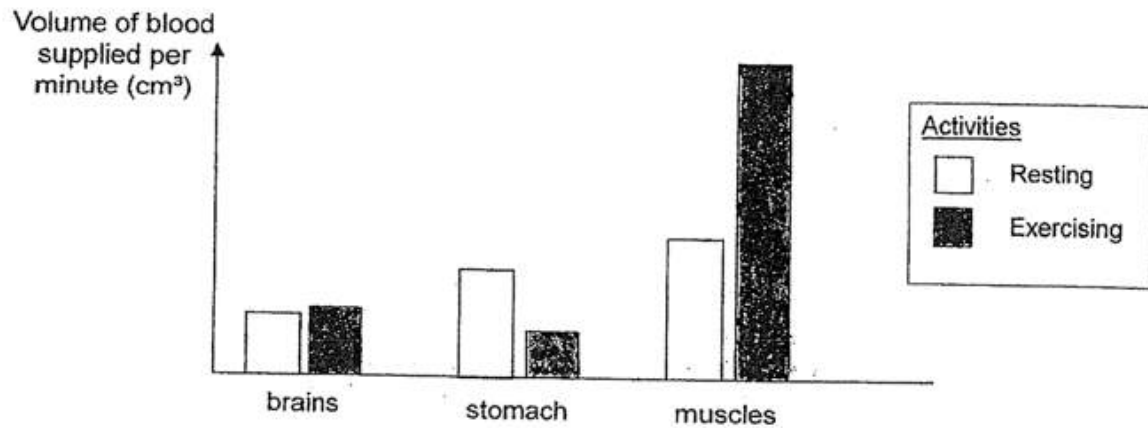

- (a) Explain why more blood is carried to the muscles when Melvin is exercising.

[2]

Question 34 of 59

Primary 6 Science (Prelim) 0 pts

- b) Based on the graph above, explain why it is not advisable for Melvin to run immediately after having a heavy meal

Question 35 of 59

Primary 6 Science (Prelim) 0 pts

- Jane prepared the set-ups to investigate the digestion rate of meat cubes as shown below. Liquid X helps in the digestion of food.



Set-up A
10 g meat cube
+
25 cm³ of liquid X



Set-up B
10 g meat cube
chopped into pieces
+
25 cm³ of liquid X

Jane observed the amount of time it took for the meat cubes to be broken down completely in each test tube. She recorded her results in the table below.

Set-up	Result
A	Meat was broken down completely after 2 hours.
B	Meat was broken down completely after 1 hour.

- (a) Which variable was changed as part of the experiment?

[1]

Question 36 of 59

Primary 6 Science (Prelim) 0 pts

- b) Based on the results above, explain how chewing of food affects the rate of digestion

Question 37 of 59

Primary 6 Science (Prelim) 0 pts

Ismail observed the growth of plant X over 5 days. He placed some seeds of plant X into a container with moist cotton wool and recorded his observations of the average length of their shoots and roots in the graph below.

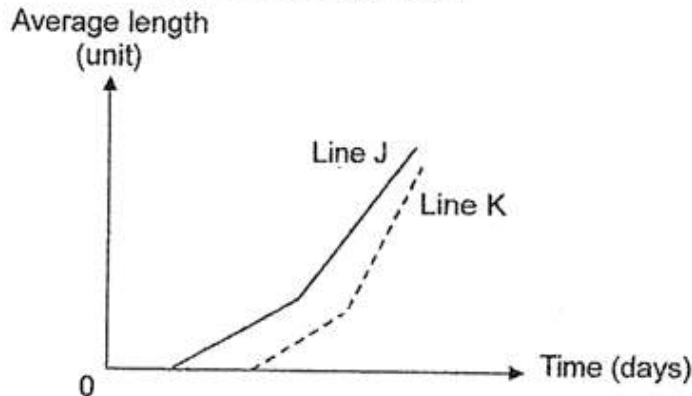

- (a) Which line, J or K, represents the growth of the roots? Explain your answer.

[1]

Question 38 of 59

Primary 6 Science (Prelim) 0 pts

- (b)(i) Draw a line graph below to show the change in the mass of seed leaves of plant X over time.

[1]

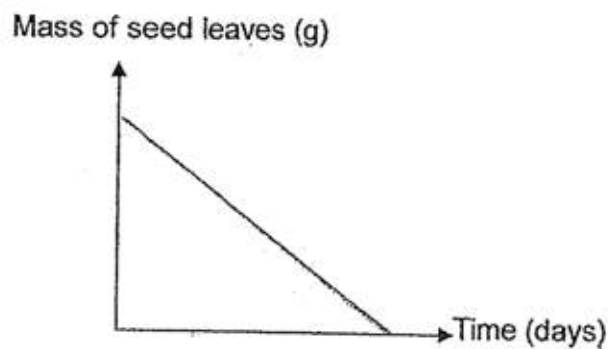
**Question 39 of 59**

Primary 6 Science (Prelim) 0 pts

- ii) Give a reason for your answer in bi)

Question 40 of 59

Primary 6 Science (Prelim) 0 pts

Mr Tan used Material Z to make sheets of different thickness in his factory. He wanted to find out how much light can pass through different thickness of Material Z using the set-up below.

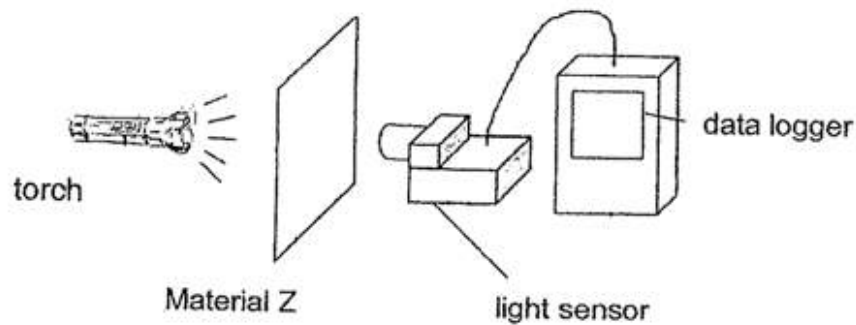

He recorded the results in the table below.

Thickness of Material Z (mm)	Amount of light recorded (unit)
1	15
2	10
3	5
4	0

- (a)(i) Mr Tan has a few sheets of Material Z that are 2mm thick. He wants to use it to wrap the outer wall of a clear plastic water bottle so that no light can enter it. Based on the above results, what is the minimum number of sheets of Material Z required?

[1]

Question 41 of 59

Primary 6 Science (Prelim) 0 pts

- aii) State another important property of Material Z that will make it suitable to be used to wrap the bottle. Explain your answer

Question 42 of 59

Primary 6 Science (Prelim)

0 pts

The diagram below shows a parking lot sensor in a carpark. When no car is parked in the lot, the light indicator turns green. When a car is parked in the lot, the light indicator turns red.

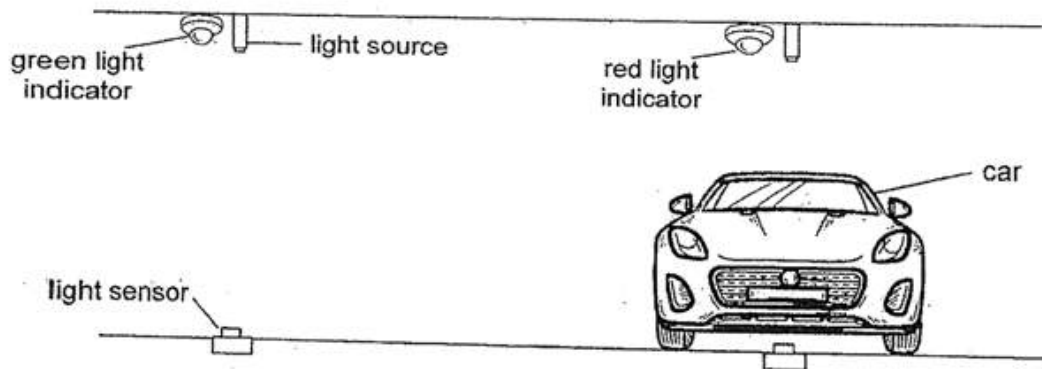

- (b) Explain how the parking lot sensor works to show when the lot is occupied and unoccupied. [2]

Question 43 of 59

Primary 6 Science (Prelim)

1 pt

Match the options below:

Kate recorded the states of three substances, J, K and L, at three different temperatures in the table below.

Substances	State of substance at		
	0°C	50°C	100°C
J	solid	liquid	gas
K	solid	solid	liquid
L	liquid	gas	gas

- (a) Arrange the three substances in order of melting point, starting from the lowest. [1]

1. [] L

A. lowest

2. [] J

B. highest

3. [] K

C. middle

Question 44 of 59

Primary 6 Science (Prelim)

0 pts

b) What is the difference between melting and evaporation?

Question 45 of 59

Primary 6 Science (Prelim)

0 pts

Kate poured substance J (in liquid form) into two identical cups, A and B. She placed each cup in two rooms, each at different temperatures. After some time, she observed more water droplets forming on cup A than B as shown below.

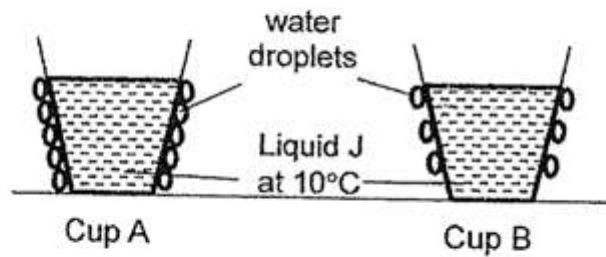

Suggest a reason for Kate's observation. Explain your answer.

[2]

Question 46 of 59

Primary 6 Science (Prelim) 0 pts

Betsy is going night cycling with her friends. In order to remain visible to other road users, she installed a headlight to her bicycle connected to a circuit as shown below.

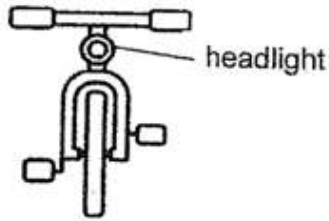

Front view of bicycle

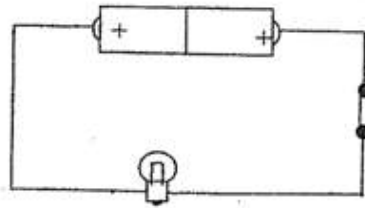

Circuit of headlight

- (a) Betsy noticed that the bulb did not light up in the circuit above. Draw in the box provided below how she should rearrange the components in the circuit for the bulb to light up. (One battery and one bulb have been drawn for you.)

[1]

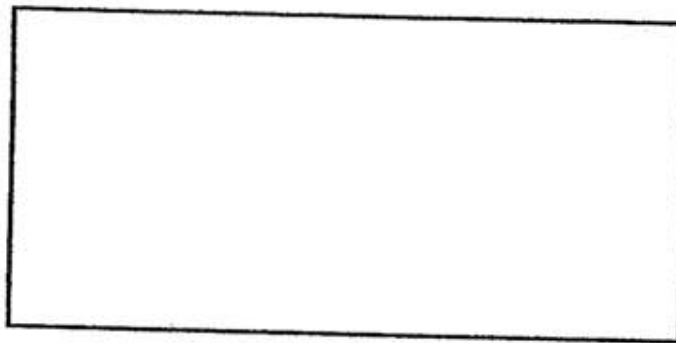

Question 47 of 59

Primary 6 Science (Prelim) 0 pts

- (b)(i) Betsy then decided to install two headlights for her bicycle. She wanted to make sure that one bulb will still work even if the other bulb is fused. Complete the circuit diagram below for the new headlights by drawing in the missing wires.

[2]

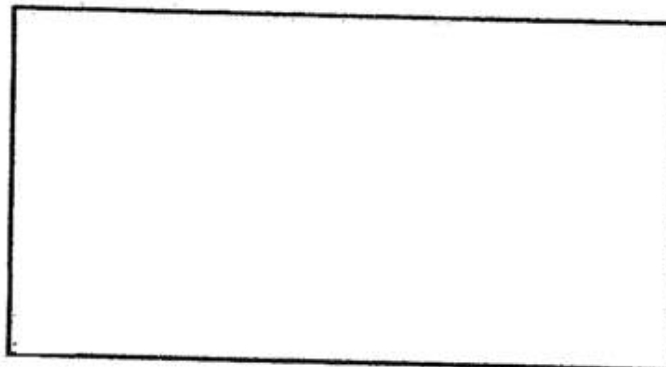

Question 48 of 59

Primary 6 Science (Prelim) 0 pts

ii) Suggest another advantage of the arrangement of the two headlights in (i) that would help Betsy keep safe when she cycles at night

Question 49 of 59

Primary 6 Science (Prelim) 0 pts

Larry tested four different surfaces W, X, Y and Z. He used an electric toy car to pull the same wooden block across each surface covering the same distance D.

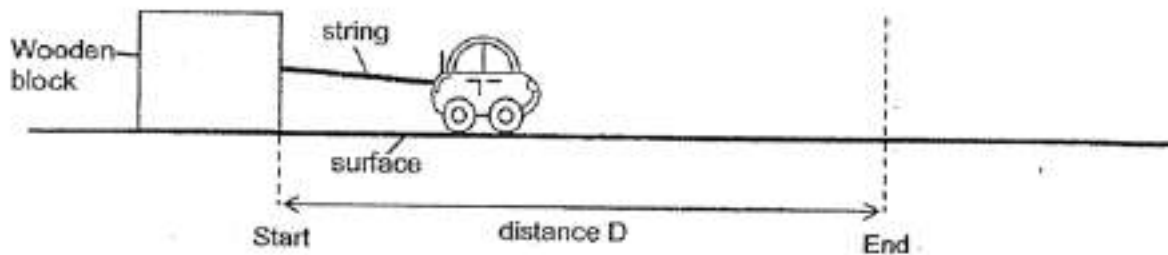

He recorded the time taken for the wooden block to move across distance D on each surface in the table below.

Surface	Time (s)
W	9
X	7
Y	3
Z	15

(a) State two forces that are acting on the wooden block as it is pulled by the car. [1]

Question 50 of 59

Primary 6 Science (Prelim) 0 pts

b) Explain why the time taken for the wooden block to move across distance D on the different surfaces is different

Question 51 of 59

Primary 6 Science (Prelim) 0 pts

In many countries, a special surface is used on the portion of the road just before traffic light junctions to prevent accidents from happening.

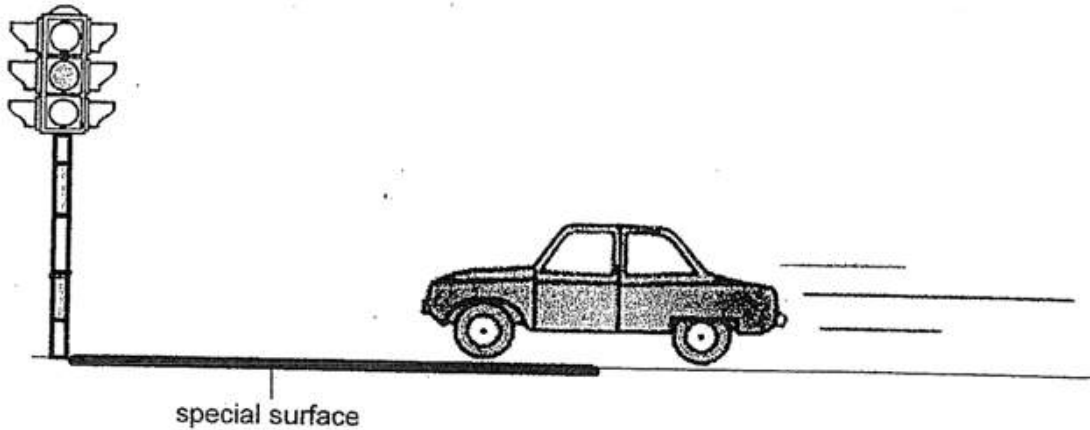

- (c) Based on Larry's results, which surface, W, X, Y or Z is most suitable for the above purpose? Explain your answer. [2]

Question 52 of 59

Primary 6 Science (Prelim) 0 pts

14

The diagram below shows carts P and Q used at a coal mine which were along a rail. When an empty cart P rolled down the rail, it hit a stationary cart Q in front of it. As a result, the stationary cart Q was pushed a distance of four metres forward.

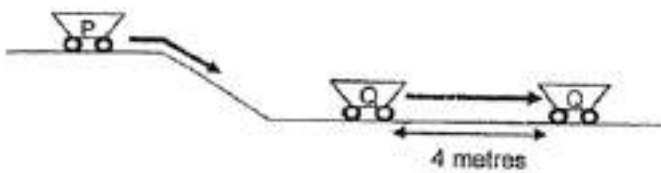

- (a) Write down the energy conversion from one form to another in the boxes below. [2]

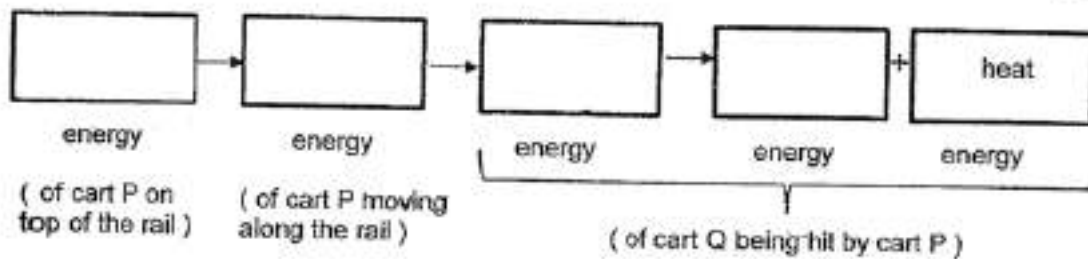

Question 53 of 59

Primary 6 Science (Prelim) 0 pts

b) If the moving cart P was fully loaded with coals, would the distance moved by cart Q be longer or shorter than 4 metres? Explain your answer in terms of energy conversion

Question 54 of 59

Primary 6 Science (Prelim) 0 pts

Rashid conducted an experiment using set-ups X and Y as shown below. He wrapped a glass beaker with material A and another identical glass beaker with material B. He filled both beakers with the same volume of hot water.

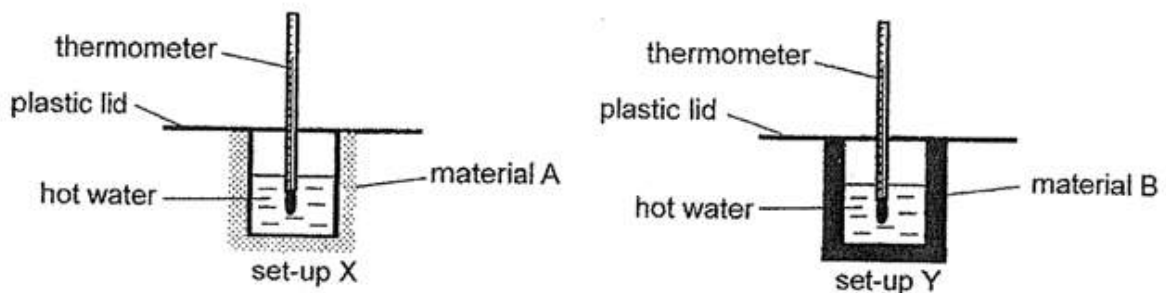

Rashid measured the temperatures of the water over a period of time and plotted his results in the graph shown.

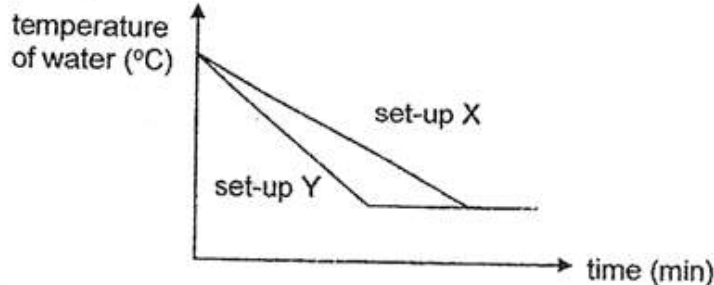

(a) What happened to the temperature of water in set-ups X and Y after some time? [1]

Question 55 of 59

Primary 6 Science (Prelim) 0 pts

b) Explain why the temperature of water in set-up X decreased at a faster rate.

Question 56 of 59

Primary 6 Science (Prelim) 0 pts

C) Material A in set-up X has small air spaces and is used to make a cooler box to store frozen food. Explain why material A would help keep the frozen food cold for a longer period of time

Question 57 of 59

Primary 6 Science (Prelim) 0 pts

Jimmy set up an experiment using a launcher and steel ball as shown below. He pulled spring X back using the handle and released it. He observed that the steel ball started to move and after passing point P, it rolled faster. It hit object A and stopped moving without bouncing back.

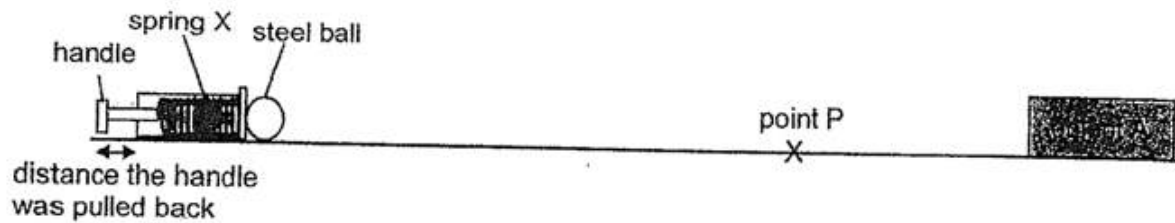

(a) Based on Jimmy's observation, what could object A be? Give a reason for your answer.

[1]

Question 58 of 59

Primary 6 Science (Prelim) 0 pts

Jimmy then removed object A and repeated his experiment with spring X and spring Y. He pulled each spring back at different distances before releasing the handle and measured the distance travelled by the ball. The graph below shows the results he obtained.

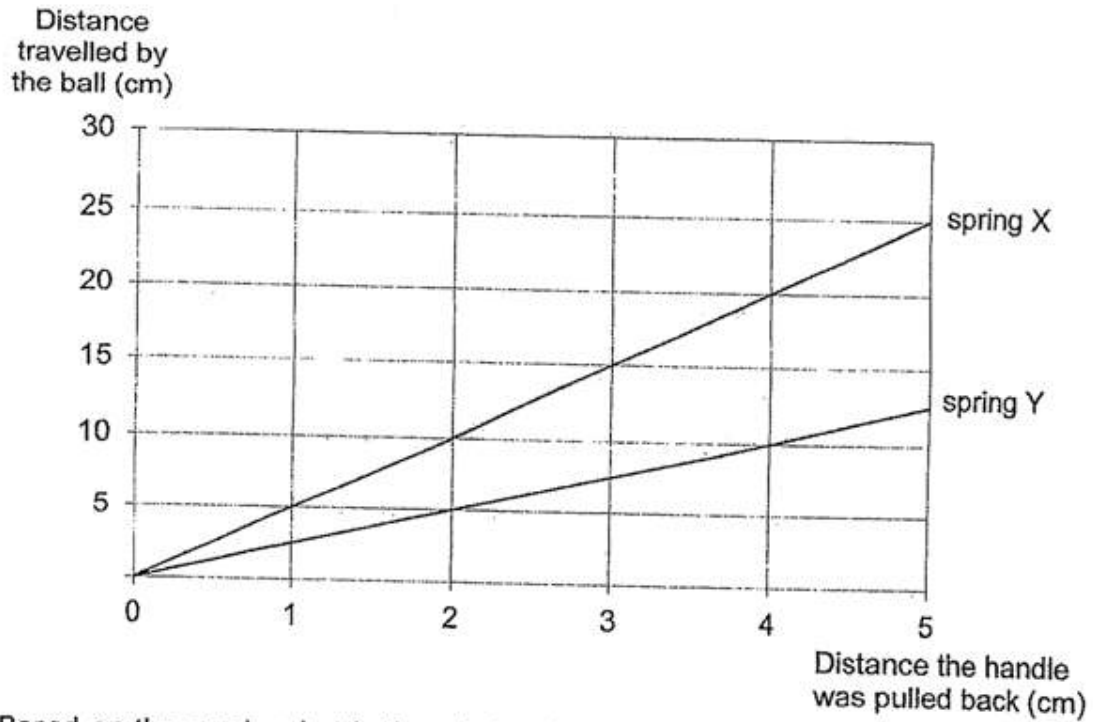

- (b) Based on the graph, what is the relationship between the amount of elastic spring force and the distance travelled by the ball? [1]

Question 59 of 59

Primary 6 Science (Prelim)

0 pts

Jimmy wanted to build a rocket launcher as shown below.

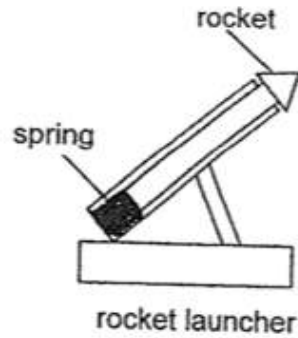

- (c) Based on the graph, which spring, X or Y, should he choose so that his rocket can fly as high as possible? Explain your answer. [2]
-